

DCM
LOUDSPEAKERS

DCM
LOUDSPEAKERS

282 Carver Street
Winslow, IL 61089
Phone (877)DCM-LOUD

Visit our Internet web site at: www.dcmspeakers.com

DCM is a registered trademark of Mitek Corporation.

Due to our policy of continuous improvement, specifications are subject to change without notice.

21A6336



TB1
Powered Home Subwoofer
Owner's Manual

CARE AND MAINTENANCE

Your speakers are designed to work with a wide range of electronic components. As little as 20 watts per channel can provide enough power for most applications. If you have a large room or prefer louder listening levels, more power may be required.

Caution: When choosing an amplifier, do not exceed the power rating of the speaker. If you hear very high levels of audible distortion you are exceeding the capabilities of the system. Damage can occur from this distortion, turn the volume back down until the distortion disappears.

Use the following guidelines to maintain the appearance of your speakers. Use a soft, damp cloth to clean the speaker cabinet. Avoid using harsh detergents or cleaning fluids. Remove the grills to vacuum any of the speaker components, permanent damage could occur.

TECHNICAL ASSISTANCE

For additional technical assistance you can visit our web site at www.dcmspeakers.com. Otherwise, our technical service representatives can be reached by phone: 1-800-DCM-LOUD or by E-mail: technical@dcmspeakers.com.

TWO YEAR LIMITED WARRANTY

DCM Loudspeakers purchased in the United States from an authorized DCM dealer are guaranteed against defective material and workmanship for a period of TWO YEARS from the date purchased by the end user, and limited to the original retail purchaser of the product. Product found to be defective during that period will be repaired or replaced by DCM at no charge. This warranty is void if it is determined that unauthorized parties have attempted repairs or alterations of any nature. Warranty does not extend to cosmetic or finish. Before presuming a defect is present in the product, be certain that all related equipment and wiring is functioning properly. DCM disclaims any liability for other incurred damages resulting from product defects. Any expenses incurred in the removal and reinstallation of products are not covered by this warranty. DCM's total liability will not exceed the purchase price of the product. If a defect is present, your authorized DCM dealer may be able to effect repairs.

Proof of purchase is required when requesting service, so please retain your sales receipt and take a moment to register your warranty on line @www.dcmspeakers.com.

SPECIFICATIONS

Amplifier Type:	Class A/B
Frequency response:	40 Hz - 160 Hz
Lo-pass xover	60 Hz - 160 Hz at 18 dB per octave
Inputs:	Line level and speaker level full range
Outputs:	Line level
Hi-pass subsonic filter:	18 dB per octave below 30 Hz
Polarity switch:	Normal (0 degrees)/reverse (180 degrees)

Amplifier

Power: (continuous) 100 watts

Driver

Size: 10"

Voice coil diameter: 1-1/2"

Dimensions

Height: 15-1/2"

Width: 15"

Depth: 17"

Weight

System: 34.5 lbs

Shipping: 41.5 lbs

Specifications subject to change without notice.

SAFETY SYMBOLS AND STATEMENTS



CAUTION
RISK OF ELECTRIC SHOCK DO NOT OPEN
WARNING: SHOCK HAZARD, DO NOT OPEN. AVIS: RISQUE DE CHOC ELECTRIQUE - NE PAS OUVRIIR.
CAUTION: TO REDUCE THE RISK OF ELECTRIC SHOCK DO NOT REMOVE COVER (OR BACK) NO USER SERVICEABLE PARTS INSIDED REFER SERVICING TO QUALIFIED PERSONNEL



The lightning flash with arrowhead symbol, within an equilateral triangle, is intended to alert the user to the presence of uninsulated "dangerous voltage" within the product's enclosure that may be of sufficient magnitude to constitute a risk of electric shock to persons.

The exclamation point within an equilateral triangle is intended to alert the user to the presence of important operating and maintenance (servicing) instructions in the literature accompanying the product.

CAUTION: TO PREVENT ELECTRIC SHOCK, MATCH WIDE BLADE OF PLUG TO WIDE SLOT, FULLY INSERTED.



IMPORTANT SAFETY INSTRUCTIONS

1. **Read Instructions** – All the safety and operating instructions should be read before the product is opened.
2. **Retain Instructions** – The safety and operating instructions should be retained for future reference.
3. **Heed Warnings** – All warnings on the product and in the operating instructions should be adhered to.
4. **Follow Instructions** – All operating and use instructions should be followed.
5. **Cleaning** – Unplug this product from the wall outlet before cleaning. Do not use liquid cleaners or aerosol cleaners. Use a damp cloth for cleaning. **Exception:** A product that is meant for uninterrupted service and that for some specific reason, such as the possibility of the loss of an authorization code for a CATV Converter, is not intended to be unplugged by the user for cleaning or any other purpose, may exclude the reference to unplugging the product in the cleaning description otherwise required in above 5).
6. **Attachments** – Do not use attachments not recommended by the product manufacturer as they may cause hazards.
7. **Water and Moisture** – Do not use this product near water – for example, near a bath tub, wash bowl, kitchen sink, or laundry tub; in a wet basement; or near a swimming pool; and the like.
8. **Accessories** – Do not place this product on an unstable cart, stand, tripod, bracket, or table. The product may fall, causing serious injury to a child or adult, and serious damage to the product. Use only with a cart, stand, tripod, bracket, or table recommended by the manufacturer, or sold with the product. Any mounting of the product should follow the manufacturer's instructions, and should use a mounting accessory recommended by the manufacturer.
9. **A product and cart combination should be moved with care.** Quick stop, excessive force, and uneven surfaces may cause the product and cart combination to overturn.
10. **Ventilation** – Slots and openings in the cabinet are provided for ventilation and to ensure reliable operation of the product and to protect it from overheating, and these openings must not be blocked or covered. The openings should never be blocked by placing the product on a bed, sofa, rug or other similar surface. This product should not be placed in a built-in installation such as a bookcase or rack unless proper ventilation is provided or the manufacturer's instructions have been adhered to.
11. **Power Sources** – This product should be operated only from the type of power source indicated on the marking label. If you are not sure of the type of power supply to your home, consult your product dealer or local power company. For products intended to operate from battery power, or other sources, refer to the operating instructions.
12. **Grounding or Polarization** – This product may be equipped with a polarized alternating-current line plug (a plug having one blade wider than the other). This plug will fit into the power outlet only one way. This is a safety feature. If you are unable to insert the plug fully into the outlet, try reversing the plug. If the plug should still fail to fit, contact your electrician to replace your obsolete outlet. Do not defeat the safety purpose of the polarized plug.
13. **Power-Cord Protection** – Power-supply cords



should be routed so that they are not likely to be walked on or pinched by items placed upon or against them, paying particular attention to cords at plugs, convenience receptacles, and the point where they exit from the product.

15. **Outdoor Antenna Grounding** – If cable system is connected to the product, be sure the cable system is grounded so as to provide some protection against voltage surges and built-up static charges.
16. **Lightning** – For added protection for this product during a lightning storm, or when it is left unattended and unused for long periods of time, unplug it from the wall outlet and disconnect the antenna or cable system. This will prevent damage to the product due to lightning and power-line surges.
17. **Overloading** – Do not overload wall outlets, extension cords, or integral convenience receptacles as this can result in a risk of fire or electric shock.
18. **Object and Liquid Entry** – Never push objects of any kind into this product through openings as they may touch dangerous voltage points or short-out parts that could result in a fire or electric shock. Never spill liquid of any kind on the product.
19. **Servicing** – Do not attempt to service this product yourself as opening or removing covers may expose you to dangerous voltage or other hazards. Refer all servicing to qualified service personnel.
20. a) When the power-supply cord or plug is damaged.
b) If liquid has been spilled, or objects have fallen into the product.
c) If the product has been exposed to rain or water.
d) If the product does not operate normally by following the operating instructions. Adjust only those controls that are covered by the operating instructions as an improper adjustment of other controls may result in damage and will often require extensive work by a qualified technician to restore the product to its normal operation.
e) If the product has been dropped or damaged in any way.
21. **Replacement Parts** – When replacement parts are required, be sure the service technician has used replacement parts specified by the manufacturer or have the same characteristics as the original part. Unauthorized substitutions may result in fire, electric shock, or other hazards.
22. **Safety Check** – Upon completion of any service or repairs to this product, ask the service technician to perform safety checks to determine that the product is in proper operating condition.
23. **Wall or Ceiling Mounting** – The product should be mounted to a wall or ceiling only as recommended by the manufacturer.
24. **Heat** – The product should be situated away from heat sources such as radiators, heat registers, stoves, or other products (including amplifiers) that produce heat.

IN CASE OF TROUBLE

Your new subwoofer, once set-up and adjusted, should give you years of listening enjoyment with your favorite movies and music. However, if you should experience a problem with your unit, the following chart should help you locate the trouble:

Problem

- 1) Subwoofer makes loud noise at turn-on.
- 2) Subwoofer has no output.
 - a) Status LED off
 - b) Red light on
 - c) Green light on
- 3) Subwoofer has little output.
- 4) Subwoofer output is distorted at high volume.
- 5) Subwoofer output is distorted at low volume.
- 6) Subwoofer makes hum or buzzing noises.

Diagnosis

- A) Muting circuit is defective. Return unit for repair.
 - A) Line cord is not plugged in.
 - B) Line fuse is blown. Unplug line cord from wall outlet, then check fuse.
 - C) Internal fuse is blown. Return unit for repair.
- A) No signal is reaching the unit. Check connections from receiver or preamplifier.
- B) Power switch is turned off. Place switch to "stand by" or "on" mode.
 - A) Signal is present, but input level control is set at minimum.
 - A) Input level control is set too low.
 - B) If using high level inputs, right and left channels are connected out of phase. Check wiring.
 - A) Volume of subwoofer is too high, causing amplifier to be over driven. Reduce setting of input level control.
 - B) Signal from receiver, amplifier, or preamplifier is distorted from being over driven. Reduce main system volume or bass tone control.
 - C) Subwoofer electronics are defective. Return unit for repair.
 - A) Signal from receiver, amplifier, or preamplifier is distorted from defective electronics.
 - B) Signal connecting wires to subwoofer are shorted. Check wiring.
 - C) Subwoofer electronics are defective. Return unit for repair.
 - A) Grounding problem or ground loop condition. Check wiring.
 - B) Isolate problem by removing all connecting cables and turning up subwoofer input level control. If noise is still present, subwoofer electronics are defective. Return unit for repair.

OPERATION

After you have connected your subwoofer, adjusted it for proper operation with the rest of your system, and experimented to find the best location for it, it's time to sit back and enjoy it. As you do, here are some hints for getting the most out of your subwoofer.

A) The subwoofer's level control is designed to adjust the balance between your subwoofer and main stereo speakers and should not be used as a substitute for the bass or loudness controls on your amplifier or receiver. If more bass is desired, advance the bass or loudness controls on your main amplifier or receiver.

B) Your subwoofer's auto turn-on-turn-off feature allows "set it and forget it" operation by keeping the electronics in a standby mode until a signal is detected, which turns the amplifier on instantly. When there is no signal present after a few minutes, the electronics will again shut down to the standby mode. We do suggest that you turn the subwoofer off by its power switch if it is to be unused for an extended period of time. For additional protection against damage from lightning, we recommend unplugging the line cord.

C) The tone controls on your preamplifier, receiver, or amplifier should be used with caution and care. Excessive boost in certain frequency ranges can cause heavy demands on amplifier and loudspeaker components resulting in overheating, distortion, mechanical overload, and premature failure.

CARE AND CLEANING

Your subwoofer is finished in a durable vinyl and may be wiped clean with a damp cloth as needed when the power switch is turned off.



POWERED HOME SUBWOOFER OWNER'S MANUAL

Table of Contents

<i>Introduction</i>	<i>2</i>
<i>Unpacking/pre-installation instructions</i>	<i>3</i>
<i>Glossary.....</i>	<i>3</i>
<i>Explanation of features and controls</i>	<i>4</i>
<i>Placement or positioning</i>	<i>6</i>
<i>Wiring and connections</i>	<i>7</i>
<i>Set-up and adjustment</i>	<i>11</i>
<i>Operation.....</i>	<i>12</i>
<i>Care and cleaning</i>	<i>12</i>
<i>In case of trouble.....</i>	<i>13</i>
<i>Specifications.....</i>	<i>14</i>

CONGRATULATIONS...

... on your purchase of a DCM powered home subwoofer system. Your new subwoofer is one of the most exciting home entertainment electronic products available, adding impact and realism to recorded music and the wide variety of movies to be found on videotape, laser disc, DVD and off-the-air broadcasts.

Once set-up and properly adjusted, it should give you many years of entertainment pleasure.

Your subwoofer is a high value product built in America using the latest materials, technology, and equipment by DCM, a vertically integrated company. Thank you for selecting DCM in making your audio equipment purchase.

INTRODUCTION

Your new subwoofer has many features which help to deliver its great bass performance and make it a remarkable value in home theater products.

*** High efficiency amplifier:**

Your home subwoofer utilizes a modern class A/B amplifier circuit to produce high power with a minimum of heat.

*** Versatile hook-up and operation:**

Your new subwoofer has a variety of input and output connections that make it easy to set-up and use in almost any stereo or home theatre system.

*** Low distortion woofers:**

Each woofer uses an overhung voice coil and large excursion suspension to produce higher sound pressure levels with lower distortion.

*** Optimal enclosures:**

Each enclosure is designed to match the parameters of its woofer to maximize performance. Special low noise vents are used for less distortion at the bottom of the frequency range.

SET-UP AND ADJUSTMENT

After you have selected an initial location for your subwoofer and have connected it into your system, have a seat in your normal listening position and have someone help you with the following adjustments:

A) If you are using the line level inputs and your main speakers are receiving a full range signal, set the subwoofer crossover frequency control to its full counterclockwise position of 60 Hz.

B) Set the polarity switch to the "normal" position and the level control to the full counterclockwise position at "minimum".

C) Turn off the loudness control and set the bass tone control on your main amplifier to the flat position.

D) Use familiar program material that has substantial bass content and play your main system at a moderate volume level.

E) Slowly rotate the subwoofer level control clockwise until a good balance is achieved between the low frequency output of your subwoofer and the mid bass and upper frequencies from your main speakers.

F) Change the polarity switch from "normal" to "reverse" to determine which position results in the most overall bass output. Leave the switch in the position that gives the highest output level.

G) Slowly rotate the subwoofer crossover frequency control clockwise to attain the best blend between the level of the subwoofer and the main speakers in the midbass crossover region. Advancing the control too far will cause a "boominess" in the overall sound and will add an unnatural "chesty" quality to male voices.

B) For use with A/V preamps and receivers that have 5.1 channel line level outputs.

If your preamplifier or receiver has a single “subwoofer” output or “LFE” output, connect a shielded cable from the preamplifier output to either one of the subwoofer line level inputs. Refer to Figure E.

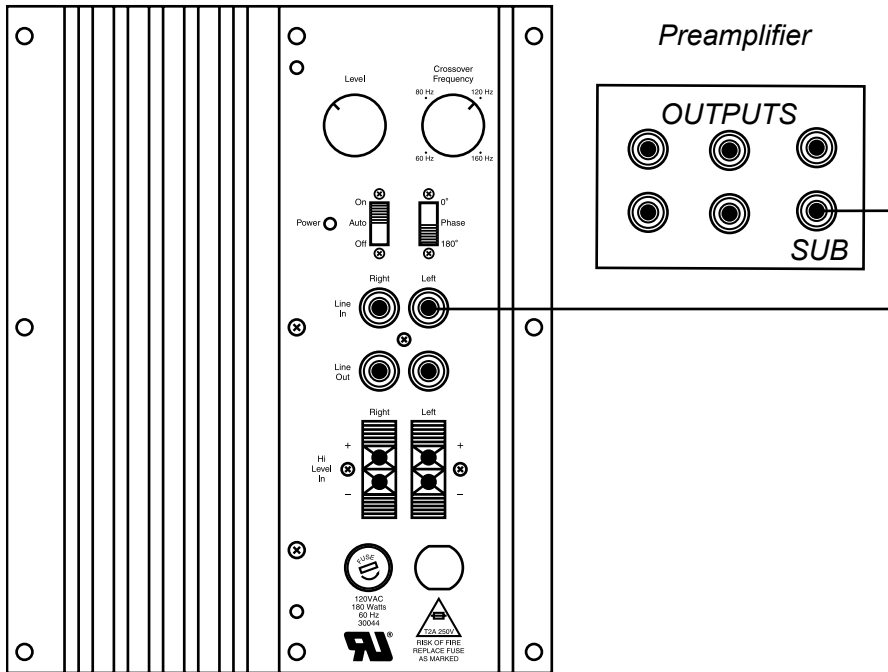

FIGURE E

UNPACKAGING/PRE-INSTALLATION INSTRUCTIONS

Unpack your new subwoofer carefully, keeping the carton and packing material for future use. Check the condition of your unit, reporting any damage which may have occurred in transit to your dealer or shipping company.

GLOSSARY

The following list of terms with their definitions is offered as a help in understanding the set-up and operation of your subwoofer.

Crossover (xover) - an electrical filter with lo-pass or hi-pass characteristics that divides the frequency range into bands of low, middle, or high frequencies to match the capabilities of specialized loudspeakers like subwoofers that are only effective at reproducing limited frequency ranges. The crossover frequency is the frequency where the filter begins to attenuate or reduce the level of the signal.

Full range - refers to signals which cover the entire audio frequency span from 20 Hz to 20 kHz.

Hi-pass - a type of filter circuit that allows high frequencies to pass, while reducing the level of low frequencies with the transition from high to low occurring at the crossover frequency. The rate of reduction of the signal is called the attenuation rate or slope and is measured in decibels (dB) over a change in frequency of one octave which is a doubling or halving of frequency.

Impedance - the resistance to the flow of current in an alternating current circuit (such as with music). Line level circuits are typically a high impedance of several thousand ohms, while speaker level circuits are usually a low impedance of a few ohms.

Line level - the type of signal produced at the outputs of preamplifiers, tape decks, CD players, etc., with a typical value of a volt or less in a high impedance circuit. Sometimes called low level signals, they are routed using shielded cables which are usually terminated with RCA phono connectors.

Lo-pass - a type of filter circuit that allows low frequencies to pass, while reducing the level of high frequencies with the transition from low to high occurring at the crossover frequency. The rate of reduction is called the attenuation rate or slope and is measured in decibels (dB) over a change in frequency of one octave which is a doubling or halving of frequency.

Speaker level - the type of signal produced at the outputs of power amplifiers that may be many volts in a low impedance circuit. Sometimes called high level signals, they are routed using two conductor unshielded wire of 18 gauge or larger. Connections are usually made with stripped ends of wire gripped in spring loaded terminals.

EXPLANATION OF FEATURES AND CONTROLS

Refer to figure A.

1) **Polarity switch:** This two position switch allows the best match of acoustic output between the subwoofer and the main stereo speakers in the region of the crossover frequency between them. The “normal” position maintains phase from input to output, the “reverse” position changes polarity or phase by 180 degrees.

2) **Power switch:** This three position switch controls the power status of the subwoofer.

Off: Turns the unit off.

Auto: Places the unit in the standby mode, in this mode the subwoofer will automatically turn on when an audio signal is applied to either the high or low level inputs.

On: Turns the unit on regardless of whether a signal is present or not.

3) **Subwoofer crossover :** This rotary control adjusts a variable low pass filter to set the upper frequency at which the output of the subwoofer begins to roll-off. Continuously variable from 60 Hz to 160 Hz, it matches the upper frequency characteristics of the subwoofer to the low frequency response of the main stereo speakers.

4) **Line level output:** These RCA phono jacks provide a line level, stereo output that tracks the level of the full range signal at the line level or speaker level input. This output is provided for those wishing to “bi-amplify” their main stereo speakers.

5) **Line level input:** These RCA phono jacks accept a line level full range signal from the preamplifier output of a receiver or preamplifier. This full range signal is processed and amplified to power the subwoofer.

6) **Speaker level input:** These spring loaded terminals for speaker wire accept a stereo, speaker level, full range signal from a receiver or power amplifier. This signal is processed and amplified to power the subwoofer.

7) **Fuse:** For continued protection replace fuse with same type and size listed.

8) **Level control:** This rotary control adjusts the level of the subwoofer and is used to balance its volume with that of the main stereo speakers.

9) **Status LED:** This two color light emitting diode shows the status of the subwoofer electronics. “Red” indicates that the amplifier is plugged in and the power switch is either off or in standby mode with no input signal present. “Green” indicates that the amplifier is operating with signal present at the input from the preamplifier, receiver, or power amplifier.

Installation using line level inputs

A) Using a preamp or receiver with line level outputs.

If a preamplifier output is available on your receiver, or you have a preamplifier, connect it to the stereo line level RCA type input jacks on your subwoofer. Use quality shielded cables and connectors. Connect one set of shielded cables from the preamplifier output to the subwoofer input. Connect a second set of cables from the subwoofer outputs to the input of the power amplifier for your main stereo speakers.

Note: Do not use the tape monitor output from your receiver or preamplifier because its signal level will not vary with the setting of the preamp volume control.

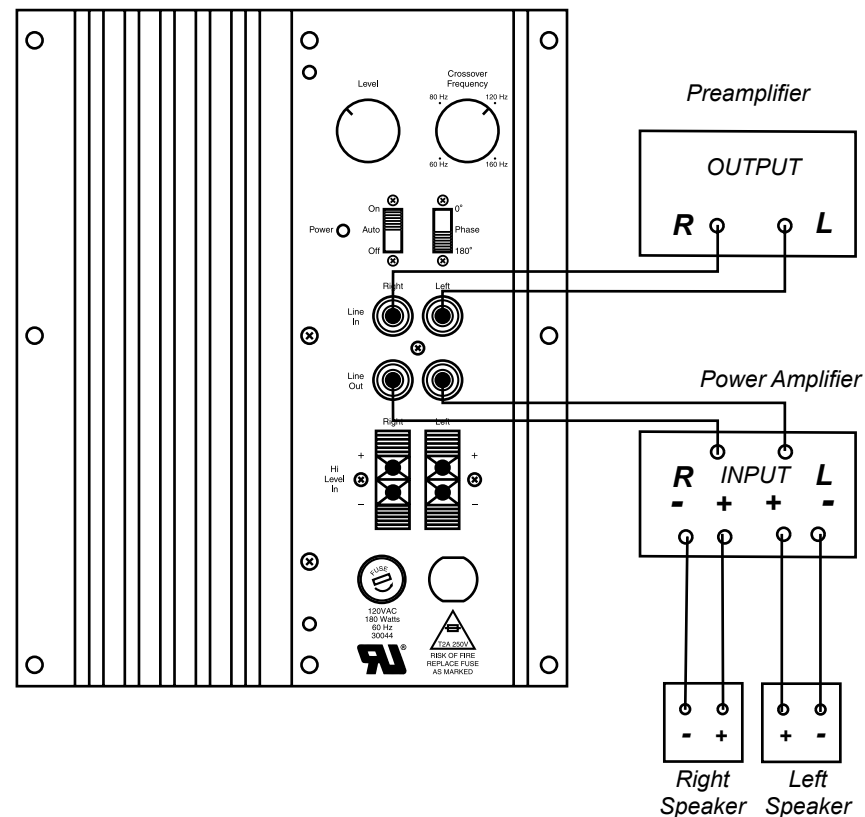

FIGURE D

B) For amplifiers with two sets of speaker connections.

An alternate method of connecting your subwoofer and main speakers is possible if you have a receiver or amplifier that can accommodate two sets of speakers that can be switched on at the same time and be connected in parallel. (Note that some receivers and amplifiers connect "A" and "B" sets of speakers in series, not parallel. A series wiring will not allow this alternate connection method for your subwoofer. Consult the owner's manual for your receiver or amplifier to find out which type of connection is used for "A" and "B" sets of speakers.)

Make one set of connections from the "A" speaker outputs of your receiver or amplifier to the speaker level inputs of your subwoofer and another set of connections from the "B" speaker outputs of your receiver or amplifier to your main stereo speakers. Switch both "A" and "B" speakers to the "on" position. Refer to figure C.

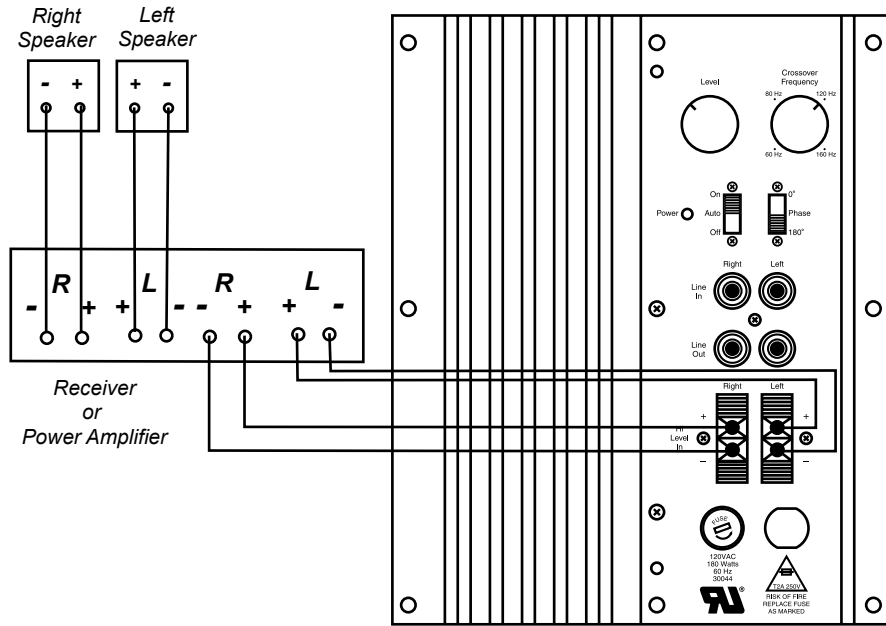

FIGURE C

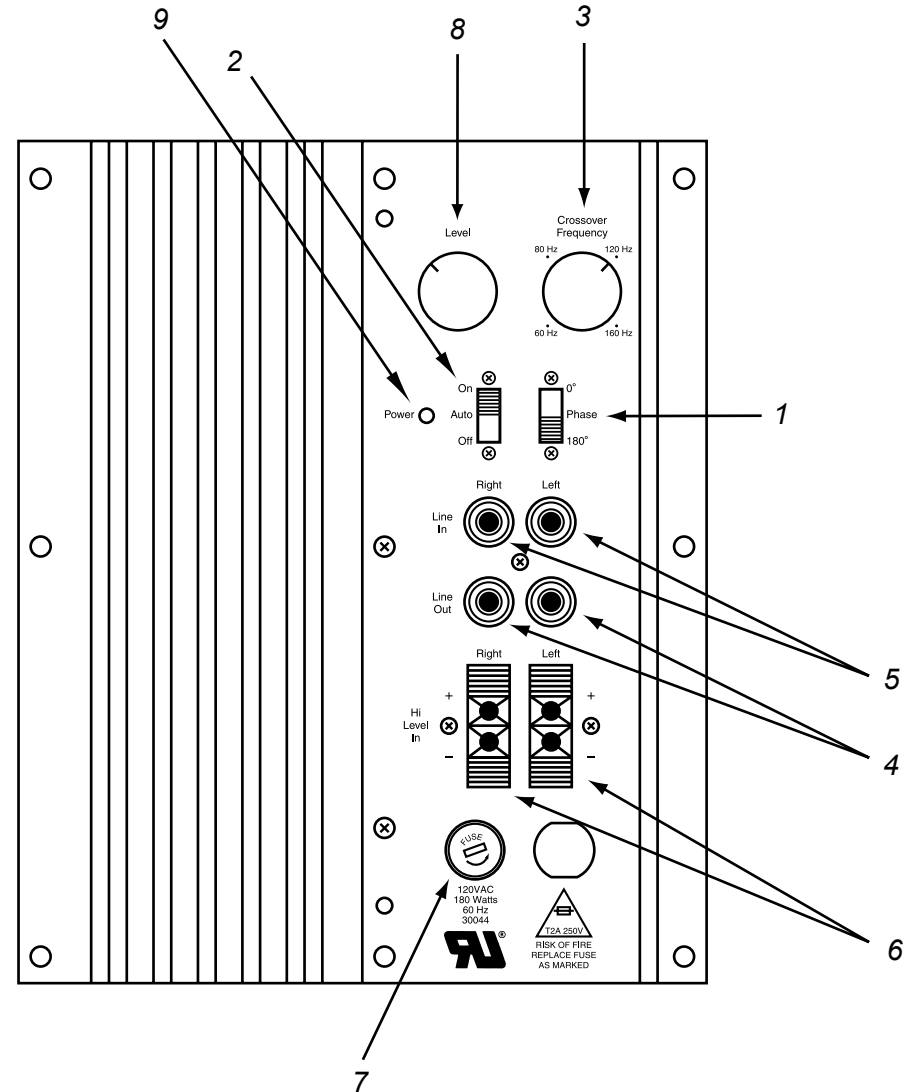

FIGURE A

PLACEMENT OR POSITIONING

Your new subwoofer will work well in a variety of locations. However, placement in your listening room will affect its performance. Since the wavelengths of sound reproduced by your subwoofer are large compared to its size, those sounds are omni-directional in nature. This means that locating your subwoofer in relation to your left and right main speakers will not affect the directional cues which they provide.

Because the sounds you hear are a combination of direct sound from the speaker and reflected sound from the walls, ceiling, and floor of your listening room, placement of the subwoofer in relation to room boundaries changes the balance of what you hear at low frequencies. In that low frequency range, the dimensions of most rooms are comparable to the wavelengths of those sounds. As sound propagates and reflects in the room, "standing waves" are created at frequencies where the wavelength of sound or multiples of the wavelength are equal to one of the dimensions of the room. At your listening position, these standing wave patterns of reflected sound add together in and out of phase causing large variations in the response that you hear.

As a general rule, locating your subwoofer near the corner of the room will increase its overall output, but will excite more standing waves in the room and may result in a more uneven response. Locating your subwoofer along a wall will usually mean less acoustic output but a somewhat smoother response. A middle of the room location would suggest the smoothest response with the least output capability. Of course, any location will be a compromise between acoustic performance and the aesthetic blend of the subwoofer enclosure with the decor and furnishings of your room. Don't be afraid to experiment with the location of your subwoofer in your room for the best results at your listening position. As with any other listening test, use program material that you are familiar with that has substantial bass content.

WIRING AND CONNECTIONS

Turn off all power to your subwoofer and other equipment before making any connections.

Installation using speaker level inputs

A) For amplifiers with one set of speaker connections.

If a preamplifier output connection is not available on your amplifier or receiver, your subwoofer can be connected using your equipment's speaker outputs. These connections are made using commonly available 18 or 16 gauge lamp cord or speaker hook-up wire. Observe correct polarity by connecting red(+) and black(-) to black(-) for both left and right channels. Connect your amplifiers speaker output terminals to the subwoofer's speaker level input terminals as well as to your main stereo speakers according to figure B.

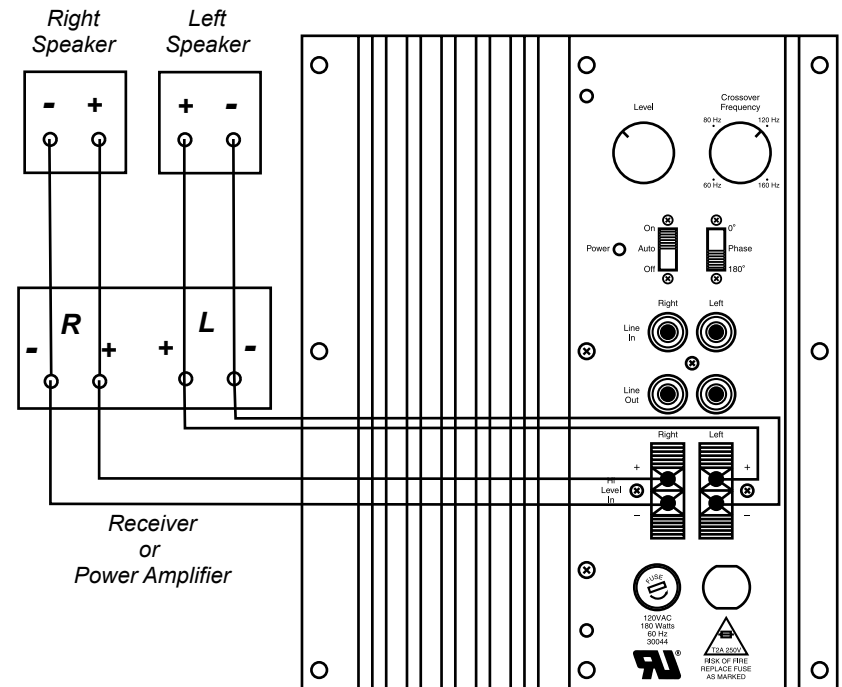

FIGURE B